

4A, 5-cell Lithium-ion Battery Charger IC With Photovoltaic Cell MPPT Function CN3865

General Description:

CN3865 is a PWM switch-mode charger controller IC for 5-cell lithium-ion batteries with few external components in small footprint package.

The CN3865 is specially designed for charging 5-cell lithium ion batteries with trickle charge, constant current and constant voltage mode. In constant voltage mode, the regulation voltage is fixed at 21V with 1% accuracy. The constant charging current is set with an external current sense resistor.

When photovoltaic cell is used as power supply, CN3865 can automatically adjust charge current to track solar panel's maximum power point.

Deeply discharged batteries are automatically trickle charged at 25% of the programmed constant charging current until the cell voltage exceeds 66.6% of regulation voltage. The charge cycle is terminated once the charging current drops to 15% of full-scale current, and a new charge cycle automatically restarts if battery voltage falls below 95.8% of regulation voltage. CN3865 will automatically enter sleep mode when input voltage is lower than battery voltage.

Other features include JEITA-compliant battery temperature monitoring, under voltage lockout, battery over voltage protection, 2 open-drain status indications, etc.

CN3865 is available in thermally-enhanced 10-pin SSOP package.

Applications:

- Electric Tools
- Emergency Lighting
- Industrial and Medical Equipment
- Standalone Charging Management

Features:

- Photovoltaic Cell Maximum Power Point Tracking
- Standalone Charge Management for 5-cell Lithium-ion Battery
- Wide Input Voltage: 6.5V to 32V
- Charge Current up to 4A
- PWM Switching Frequency: 550KHz
- Regulation Voltage: 21V \pm 1%
- Charging Current is set with a current sense resistor
- Automatic Conditioning of Deeply Discharged Batteries
- 100% Duty Cycle
- Automatic Recharge
- 2 Open-drain Status Indication
- JEITA-Compliant Battery Temperature Monitoring
- Built-in Soft Start
- Battery Over-voltage Protection
- Operating Ambient Temperature -40°C to $+85^{\circ}\text{C}$
- Available in eSSOP-10 Package
- Pb-free, Rohs-Compliant, Halogen Free

Pin Assignment:

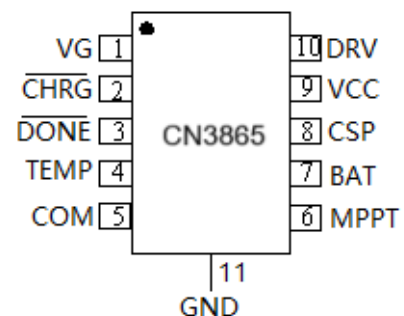

Pin 11 is the exposed PAD

CONSONANCE

Typical Application Circuit:

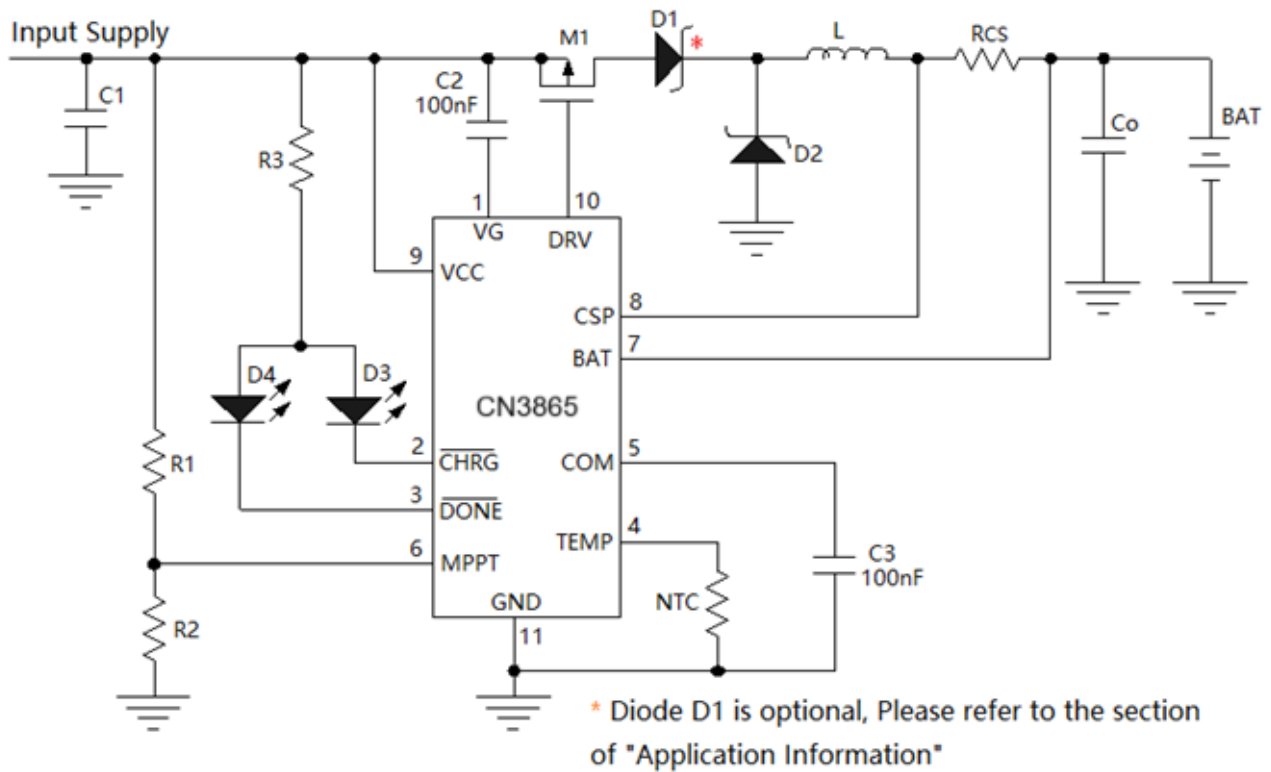

F

Figure 1 Typical Application Circuit

Ordering Information

Part No.	Package	Top Marking	Shipping	Operating Temperature Range
CN3865	eSSOP-10	CN3865	Tape and Reel, 4000/Reel	-40°C to +85°C

CONSONANCE

Pin Description:

No.	Symbol	Description
1	VG	Internal Voltage Regulator. VG internally supplies power to gate driver, connect a 100nF capacitor between VG pin and VCC pin.
2	$\overline{\text{CHRG}}$	Open-Drain Charge Status Output. When the battery is being charged, this pin is pulled low by an internal switch. Otherwise this pin is in high impedance state.
3	$\overline{\text{DONE}}$	Open-Drain Termination Status Output. When charging is terminated, this pin is pulled low by an internal switch. Otherwise this pin is in high impedance state.
4	TEMP	<p>Battery Temperature Monitoring Input. Connecting a 10KΩ NTC thermistor between TEMP pin and GND.</p> <ul style="list-style-type: none"> ● If TEMP pin's voltage is below 0.1V or above 0.85V, which means battery is too hot or too cold, charging is suspended. ● If TEMP's voltage is between 0.1V and 0.135V, which means battery is warm, charge current is reduced to 50% of full-scale current and termination voltage is reduced to 97.91%*V_{term} ● If TEMP's voltage is between 0.135V and 0.55V, CN3865 functions normally. ● If TEMP's voltage is between 0.55V and 0.85V, which means battery is cool, charge current is reduced to 25% of constant current. <p>If battery temperature monitoring function is not needed, connect a fixed 10K ohm resistor from TEMP pin to GND.</p>
5	COM	Loop Compensation Input. Connect a 100nF capacitor from this pin to GND to stabilize current and voltage regulation loops.
6	MPPT	Photovoltaic Cell Maximum Power Point Tracking Pin. Connect this pin to the external resistor divider for maximum power point tracking. In maximum power point tracking status, the MPPT pin's voltage is regulated to 1.205V.
7	BAT	Battery Voltage Sensing Input and the Negative Input for Charging Current Sensing. Externally BAT pin should be connected to positive terminal of battery to sense battery voltage. BAT pin and the CSP pin measure the voltage drop across current sense resistor R _{CS} to regulate charge current.
8	CSP	Positive Input for Charge Current Sensing. This pin and the BAT pin measure the voltage drop across current sense resistor R _{CS} to regulate charge current.
9	VCC	External DC Power Supply Input. VCC is also the power supply for internal circuit. Bypass this pin with a filtering capacitor.
10	DRV	Gate Drive Pin. Drive the gate of external P-channel MOSFET.
11	Exposed PAD	Ground (GND). The negative terminal of input power supply and battery.

CONSONANCE

ABSOLUTE MAXIMUM RATINGS

Voltage from VCC to GND.....	-0.3V to 36V	Maximum Junction Temperature.....	150°C
Voltage from $\overline{\text{CHRG}}$ to GND.....	-0.3V to 36V	Operating Temperature Range.....	-40°C to 85°C
Voltage from $\overline{\text{DONE}}$ to GND.....	-0.3V to 36V	Storage Temperature.....	-65°C to 150°C
Voltage from VG, DRV to VCC...	-8V to +0.3V	Lead Temperature(Soldering,10s).....	260°C
Voltage from CSP, BAT to GND....	-0.3V to 36V	Thermal Resistance(eSSOP10).....	TBD
Voltage TEMP to GND.....	-0.3V to 6.5V	Voltage from MPPT to GND.....	-0.3V to 6.5V
Voltage from COM to GND.....	-0.3V to 6.5V		

Stresses beyond those listed under “Absolute Maximum Ratings” may cause permanent damage to the device. These are stress ratings only, and functional operation of the device at these or any other conditions beyond those indicated in the operational sections of the specifications is not implied. Exposure to absolute maximum rating conditions for extended periods may affect device reliability.

ELECTRICAL CHARACTERICS:

((VCC = 25V, T_A = -40°C to +85°C, Typical values are at T_A = +25°C, unless otherwise noted))

Parameters	Symbol	Test Conditions	Min	Typ	Max	Unit
Input Voltage Range	VCC		6.5		32	V
Under Voltage Lockout Threshold	UVLO		3.8	5	6.3	V
Operating Current	I _{VCC}	V _{BAT} > V _{REG}	550	685	820	uA
Current Sense		V _{BAT} > V _{PRE} , V _{CSP} - V _{BAT}	88	100	112	mV
		V _{BAT} < V _{PRE} , V _{CSP} - V _{BAT}	15	25	35	
BAT Pin Current	I _{BAT1}	Termination, V _{BAT} = 22V	8	12	16	uA
	I _{BAT2}	Sleep mode, V _{BAT} = 18.5V	2.5	4.1	5.7	
Regulation Voltage (Constant Voltage Mode)	V _{REG}	Normal battery temperature	20.79	21	21.21	V
		Battery warm	20.352	20.563	20.773	
Charge Current Sense Measure (V _{CSP} - V _{BAT})	V _{CS}	V _{BAT} > V _{PRE}	88	100	112	mV
		V _{BAT} > V _{PRE} , Battery warm	40	50	60	
		V _{BAT} < V _{PRE} , Battery cool	15	25	35	
Trickle Charge						
Precharge Threshold	V _{PRE}	BAT Voltage rises	64	66.6	69	% V _{REG}
Hysteresis	H _{PRE}	BAT Voltage falls		2.5		% V _{REG}
Charge Termination						
Termination Threshold	I _{term}	Charge Current Falls		15		% I _{CC}
Recharge						
Recharge Threshold	V _{RE}	BAT falls	93	95.8	98.6	% V _{REG}
		BAT falls, Battery warm	88.5	91.6	94.7	
BAT Pin Over Voltage Protection						
Over Voltage Threshold	V _{OV}	BAT Voltage rises	1.036	1.068	1.1	V _{REG}
Over Voltage Release Threshold	V _{clr}	BAT Voltage falls	1.0	1.024	1.049	

CONSONANCE

(Continued From Last Page)

Parameters	Symbol	Test Conditions	Min	Typ	Max	Unit	
CHRG Pin							
$\overline{\text{CHRG}}$ Sink Current	I_{CHRG}	$V_{\text{CHRG}}=1\text{V}$, charge mode	7	12	18	mA	
$\overline{\text{CHRG}}$ Leakage Current	I_{LK1}	$V_{\text{CHRG}}=32\text{V}$, termination			1	uA	
DONE Pin							
$\overline{\text{DONE}}$ Sink Current	I_{DONE}	$V_{\text{DONE}}=1\text{V}$, termination	7	12	18	mA	
$\overline{\text{DONE}}$ Leakage Current	I_{LK2}	$V_{\text{DONE}}=32\text{V}$, charge mode			1	uA	
MPPT Pin							
Regulation Voltage	V_{MPPT}	MPP Tracking Mode	1.18	1.205	1.23	V	
Bias Current	I_{MPPT}		-100	0	100	nA	
Oscillator							
Frequency	f_{osc}		450	550	650	KHZ	
Maximum Duty Cycle	D_{max}				100	%	
Sleep Mode							
Sleep Mode Threshold Measure ($V_{\text{CC}}-V_{\text{BAT}}$)	V_{SLP}	VCC falls	$V_{\text{BAT}}=20\text{V}$	0.1	0.07	0.13	V
Sleep Mode Release Threshold Measure ($V_{\text{CC}}-V_{\text{BAT}}$)	V_{SLPR}	VCC rises	$V_{\text{BAT}}=20\text{V}$	0.17	0.32	0.47	V
DRV Pin							
$V_{\text{DRV High}}$ ($V_{\text{CC}}-V_{\text{DRV}}$)	V_{H}	$I_{\text{DRV}}=-10\text{mA}$		60		mV	
$V_{\text{DRV Low}}$ ($V_{\text{CC}}-V_{\text{DRV}}$)	V_{L}	$I_{\text{DRV}}=0\text{mA}$		5.5		V	
Rise Time	t_{r}	Load=2nF, 10% to 90%	30	40	65	nS	
Fall Time	t_{f}	Load=2nF, 90% to 10%	30	40	65	nS	
TEMP Pin							
TEMP Current	I_{TEMP}		27	30	33	uA	
Cold Threshold	V_{COLD}	V_{TEMP} rises, cool to cold	800	850	900	mV	
Cold Release Threshold	V_{COLDR}	V_{TEMP} falls, cold to cool	755	805	855	mV	
Cool Threshold	V_{COOL}	V_{TEMP} rises, normal to cool	510	550	590	mV	
Cool Release Threshold	V_{COOLR}	V_{TEMP} falls, cool to normal	465	505	545	mV	
Warm Threshold	V_{WARM}	V_{TEMP} falls, normal to warm	120	135	150	mV	
Warm Release Threshold	V_{WARMR}	V_{TEMP} rises, warm to normal	138	155	172	mV	
Hot Threshold	V_{HOT}	V_{TEMP} falls, warm to hot	85	100	115	mV	
Hot Release Threshold	V_{HOTR}	V_{TEMP} rises, hot to warm	105	120	135	mV	

注: V_{REG} is the regulated voltage in constant voltage mode; I_{CC} is the charge current in constant current mode.

CONSONANCE

Detailed Information:

CN3865 is a constant current, constant voltage battery charger controller IC that can be powered by the photovoltaic cell with maximum power point tracking function. The CN3865 adopts PWM step-down switching architecture, and can be used to charge 5-cell Lithium ion batteries. The charge current is set by an external current sense resistor (R_{CS}) across the CSP and BAT pins. The final battery regulation voltage in constant voltage mode is internally fixed at 21V with 1% accuracy.

A charge cycle begins when the voltage at the VCC pin rises above the UVLO level and is greater than the battery voltage by V_{SLPR} . At the beginning of the charge cycle, if the battery voltage is less than 66.6% of regulation voltage (V_{REG}), the charger goes into trickle charge mode. The trickle charge current is internally set to 25% (Typical) of the full-scale current. When the battery voltage exceeds 66.6% of regulation voltage, the charger goes into the full-scale constant current charge mode. In constant current mode, the charge current is set by the external sense resistor R_{CS} and an internal 100mV reference, the charge current equals to $100\text{mV}/R_{CS}$. When the battery voltage approaches the regulation voltage, the charger goes into constant voltage mode, and the charge current will start to decrease. When the charge current drops to 15% of the full-scale current, the charge cycle is terminated, $\overline{\text{CHRG}}$ pin outputs high impedance and $\overline{\text{DONE}}$ pin is pulled down to GND to indicate the termination status.

To restart the charge cycle, just remove and reapply the input voltage. Also, a new charge cycle will begin if the battery voltage falls below the recharge threshold of 95.8% of the regulation voltage in constant voltage mode.

The CN3865 adopts the constant voltage method to track the photovoltaic cell's maximum power point. The MPPT pin's voltage is regulated to 1.205V to track the maximum power point of the photovoltaic cell.

When the input voltage is not present, the charger automatically goes into sleep mode, all the internal circuits are shutdown.

An over-voltage comparator guards against voltage transient overshoots ($>6.8\%$ of regulation voltage). In this case, the external P-channel MOSFET is turned off until the overvoltage condition is cleared. This feature is useful for battery load dump or sudden removal of battery.

The charging profile is shown in Figure 2.

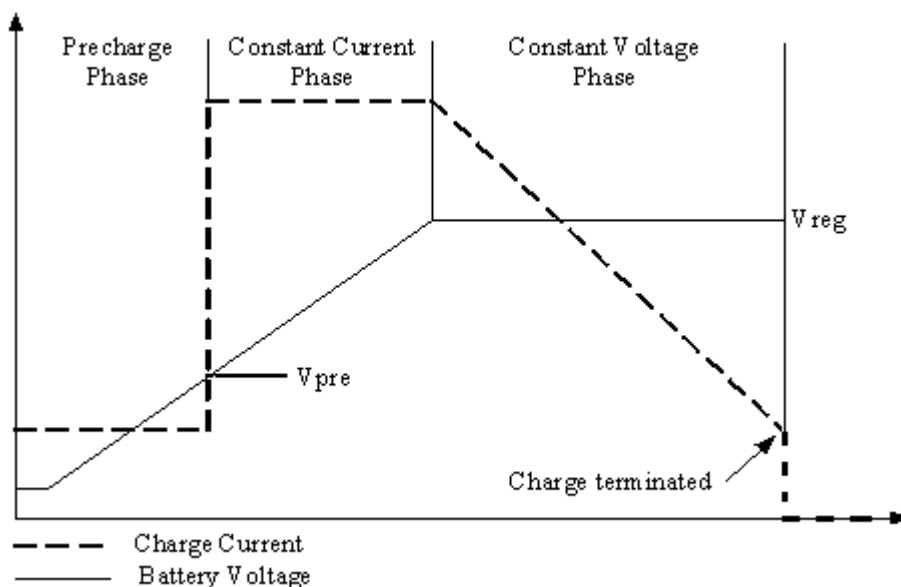

Figure 2 Charging Profile

CONSONANCE

Application Information

Under voltage Lockout (UVLO)

An under-voltage lockout circuit monitors the input voltage and keeps the charger off if VCC falls below 6.5V(Maximum).

Trickle Charge Mode

At the beginning of a charge cycle, if the battery voltage is below 66.6% of the regulation voltage, the charger goes into trickle charge mode with the charge current reduced to 25% of the full-scale current.

Charge Current Setting

The full-scale charge current, namely the charge current in constant current mode, is decided by the following formula:

$$I_{CH} = \frac{100mV}{R_{CS}}$$

Where:

I_{CH} is the full scale charge current

R_{CS} is the current sense resistor between the CSP pin and BAT pin

The Maximum Power Point Tracking

CN3865 adopts the constant voltage method to track the photovoltaic cell's maximum power point. From I-V curve of photovoltaic cell, under a given temperature, the photovoltaic cell's voltages at the maximum power point are nearly constant regardless of the different irradiances. So the maximum power point can be tracked if the photovoltaic cell's output voltage is regulated to a constant voltage.

CN3865's MPPT pin's voltage is regulated to 1.205V to track the maximum power point working with the off-chip resistor divider (R1 and R2 in Figure 1).

The maximum power point voltage is decided by the following equation:

$$V_{MPPT} = 1.205 \times (1 + R1 / R2)$$

Charge Termination

In constant voltage mode, the charge current decreases gradually. When the charge current decreases to 15% of the full-scale current, the charging is terminated. In charge termination mode, \overline{CHRG} pin outputs high impedance and \overline{DONE} pin is pulled down to GND to indicate the charge termination mode. In termination mode, the external P-channel MOSFET is turned off, no current flows to battery.

In photovoltaic cell's maximum power point tracking mode, the charging will not be terminated until the battery voltage is higher than 95.8% of the regulation voltage, even though the charge current is lower than 15% of the full-scale current.

Automatic Recharge

After the charge cycle is completed and both the battery and the input power supply (wall adapter) are still present, a new charge cycle will begin if the battery voltage falls below 95.8% of the regulation voltage in constant voltage mode.

Battery Temperature Monitoring

To prevent the damage caused by the very high or very low temperature done to the battery, the CN3865 continuously monitor battery temperature by measuring the voltage at TEMP pin which is determined by TEMP pin's source current (30uA typical) and a 10K Ω negative temperature coefficient (NTC) thermistor connected between TEMP pin and GND as shown in Figure 1.

If battery temperature monitoring function is not needed, connect a fixed 10K Ω resistor from TEMP to GND.

The battery temperature monitoring function for CN3865 is designed to follow the JEITA standard; charge current or

CONSONANCE

charge termination voltage is reduced based on battery temperature ranges.

There are totally five battery temperature ranges for CN3865:

- Hot: Above 55°C,
- Warm: 45°C to 55°C,
- Normal: 10°C to 45°C
- Cool: 0°C to 10°C,
- Cold: Below 0°C.

Normal operation occurs when battery temperature is between 10°C and 45°C, charge current and voltage will be the normal values.

When battery is in the Cool temperature range, which is between 0°C and 10°C, the charge current is 25% of full-scale charge current and charge termination voltage is not changed.

When the battery is in the Warm temperature range, which is between 45°C and 55°C, the charge current is reduced to 50% of full-scale charge current and charge termination voltage is reduced to 97.91% of nominal value.

Charging is suspended if battery temperature is below Cold temp of 0°C or above Hot temp of 55°C. When charging is suspended, both $\overline{\text{CHRG}}$ and $\overline{\text{DONE}}$ pin becomes high impedance state.

Once battery temperature is not in hot range and cold range, charging resumes automatically.

TEMP pin voltage is the product of its source current and NTC's resistance, so the selection of NTC should make sure TEMP pin voltage meet the requirements of hot, warm, cool and cold threshold. An NTC of nominal resistance 10K Ω at room temperature may be suitable for CN3865.

A resistor of small resistance in series with NTC thermistor and a resistor of large resistance in parallel with NTC thermistor can fine tune CN3865's temperature range.

The following table lists TEMP pin voltage, charge current and termination voltage in the above-mentioned 5 battery temperature range.

Battery Temperature Range	TEMP Pin Voltage	Charge Current	Termination Voltage
Hot: above 55°C	$V_{\text{TEMP}} < V_{\text{HOT}}$	Charge Suspended	Charge Suspended
Warm: 45°C to 55°C	$V_{\text{HOTR}} < V_{\text{TEMP}} < V_{\text{WARM}}$	50% * I _{CC}	97.91% * V _{TERM}
Normal: 10°C to 45°C	$V_{\text{WARMR}} < V_{\text{TEMP}} < V_{\text{COOLR}}$	Normal Value	Normal Value
Cool: 0°C to 10°C	$V_{\text{COOL}} < V_{\text{TEMP}} < V_{\text{COLDR}}$	25% * I _{CC}	Normal Value
Cold: below 0°C	$V_{\text{TEMP}} > V_{\text{COLD}}$	Charge Suspended	Charge Suspended

Status Indication

The CN3865 has 2 open-drain status output: $\overline{\text{CHRG}}$ and $\overline{\text{DONE}}$. $\overline{\text{CHRG}}$ pin is pulled down to GND when charger is in charging status, otherwise $\overline{\text{CHRG}}$ becomes high impedance. In termination status, $\overline{\text{DONE}}$ is pulled down to GND. When the battery is not present, the charger charges the output capacitor to regulation voltage or the over-voltage protection threshold quickly, CN3865 enters termination mode or over-voltage protection mode, then battery voltage decays slowly to recharge threshold or over-voltage release threshold because of discharge by the feedback resistors, CN3865 enters charge mode, and the output capacitor is charged to regulation voltage or over-voltage protection threshold again, and so forth. Then a ripple waveform is formed at charger's output, namely battery positive terminal, in the meantime, $\overline{\text{CHRG}}$ pin outputs high impedance, $\overline{\text{DONE}}$ pin outputs pulse to indicate the battery's absence. The $\overline{\text{CHRG}}$ and $\overline{\text{DONE}}$ pin should be tied to ground if not used.

The table 1 lists the indicator status and its corresponding charging status. It is supposed that red LED is connected to $\overline{\text{CHRG}}$ pin and green LED is connected to $\overline{\text{DONE}}$ pin.

CONSONANCE

$\overline{\text{CHRG}}$ Pin	$\overline{\text{DONE}}$ Pin	Description
Low (Red LED ON)	High Impedance (Green LED OFF)	Charging Status
High Impedance (Red LED OFF)	Low (Green LED ON)	Termination Status
High Impedance (Red LED OFF)	High Impedance (Green LED OFF)	There are 3 Possible Reasons: <ul style="list-style-type: none"> ● $V_{CC} < V_{UVLO}$, or ● $V_{CC} < V_{BAT}$, or ● Battery Hot or Cold

Table 1 Status Indication

Gate Drive

The CN3865's gate driver can provide high transient currents to drive the external pass transistor. The rise and fall times are typically 30ns when driving a 2000pF load, which is typical for a P-channel MOSFET with $R_{ds(on)}$ in the range of 30m Ω .

A voltage clamp is added to limit the gate drive to 7V max. below VCC. For example, if VCC is 15V, then the DRV pin output will be pulled down to 8V min. This allows low voltage P-channel MOSFETs with superior $R_{ds(on)}$ to be used as the pass transistor thus increasing efficiency.

Loop Compensation

In order to make sure that the current and the voltage regulation loops are stable, an 100nF ceramic capacitor from the COM pin to GND is necessary.

Input Capacitors

Since the input capacitor(C1 in Figure 1) is assumed to absorb all input switching ripple current in the converter, it must have an adequate ripple current rating. Worst-case RMS ripple current is approximately one-half of output charge current.

In order to depress the high-frequency oscillation during P-channel MOSFET's turning on and off, it is best that the input capacitor consists of the following 3 capacitors in parallel:

- Electrolytic capacitor for low-frequency filtering
- A ceramic capacitor from 1uF to 10uF
- A high-frequency capacitor from 47nF to 1uF

Output Capacitors

The selection of output capacitor (C_o in Figure 1) is primarily determined by the ESR required to minimize ripple voltage and load step transients. Generally a capacitor of 10uF to 47uF can meet requirements.

If only ceramic capacitor is used, care must be taken that some ceramic capacitors exhibit large voltage coefficient, which may lead to high voltage at BAT pin when battery is not present. In this case, the capacitor value should be increased properly so that no damage will be done.

Inductor Selection

During P-channel MOSFET's on time, the inductor current increases, and decreases during P-channel MOSFET's off time, the inductor's ripple current increases with lower inductance and higher input voltage. Higher inductor ripple current results in higher charge current ripple and greater core losses. So the inductor's ripple current should be limited within a reasonable range.

The inductor's ripple current is given by the following formula:

$$\Delta I_L = \frac{1}{f(L)} V_{BAT} \left(1 - \frac{V_{BAT}}{V_{CC}}\right)$$

CONSONANCE

Where,

f is the switching frequency 550KHz

L is the inductor value

V_{BAT} is the battery voltage

VCC is the input voltage

A reasonable starting point for setting inductor ripple current is $\Delta I_L \leq 0.3 \times I_{CH}$, I_{CH} is the charge current.

Remember that the maximum ΔI_L occurs at the maximum input voltage and the lowest inductor value. So lower charge current generally calls for larger inductor value.

So the inductor value should meet the requirement of the following formula:

$$L \geq \frac{V_{BAT} \cdot (VCC - V_{BAT})}{0.3 \cdot I_{CH} \cdot f \cdot VCC}$$

If solar panel is used as the input supply, the inductor value should be increased accordingly.

MOSFET Selection

The CN3865 uses a P-channel power MOSFET switch. The MOSFET must be selected to meet the efficiency or power dissipation requirements of the charging circuit as well as the maximum temperature of the MOSFET.

The peak-to-peak gate drive voltage is set internally, this voltage is typically 5.5V. Consequently, logic-level threshold MOSFETs must be used. Pay close attention to the BV_{DSS} specification for the MOSFET as well; many of the logic-level MOSFETs are limited to 30V or less.

Selection criteria for the power MOSFET includes the “on” resistance R_{ds(on)}, total gate charge Q_g, reverse transfer capacitance C_{RSS}, input voltage and maximum current.

The MOSFET power dissipation at maximum output current is approximated by the equation:

$$Pd = \frac{V_{BAT}}{VCC} \times R_{ds(on)} \times I_{CH}^2 \times (1 + 0.005 dT)$$

Where:

Pd is the power dissipation of the power MOSFET

V_{BAT} is the maximum battery voltage

VCC is the minimum input voltage

R_{ds(on)} is the power MOSFET's on resistance at room temperature

I_{CH} is the charge current

dT is the temperature difference between actual ambient temperature and room temperature(25°C)

In addition to the I²R_{ds(on)} loss, the power MOSFET still has transition loss, which are highest at the highest input voltage. Generally speaking, for V_{IN} < 20V, the I²R_{ds(on)} loss may be dominant, so the MOSFET with lower R_{ds(on)} should be selected for better efficiency; for V_{IN} > 20V, the transition loss may be dominant, so the MOSFET with lower C_{RSS} can provide better efficiency. C_{RSS} is usually specified in the MOSFET characteristics; if not, then C_{RSS} can be calculated using C_{RSS} = Q_{GD}/ΔV_{DS}.

Diode Selection

The diodes D1 and D2 in Figure 1 are schottky diode, the current rating of the diodes should be at least the charge current limit, the voltage rating of the diode should exceed the maximum expected input voltage.

The diode that is much larger than that is sufficient can result in larger transition losses due to their larger junction capacitance.

Diode D1 in Figure 1 is used as block diode to prevent battery current from flowing back to VCC when input supply is absent. Without D1, CN3865 consumes about 32uA current from battery(V_{BAT}=20V), so diode D1 can be removed if the 32uA battery current is not a concern.

CONSONANCE

PCB Layout Considerations

When laying out the printed circuit board, the following considerations should be taken to ensure proper operation of the IC.

- (1) To minimize radiation, the 2 diodes, pass transistor, inductor and the input bypass capacitor traces should be kept as short as possible. The positive side of the input capacitor should be close to the source of the P-channel MOSFET; it provides the AC current to the pass transistor. The connection between the diode and the pass transistor should also be kept as short as possible.
- (2) The grounding terminal of compensation capacitor connected at the COM pin and the resistor divider at MPPT pin should return to the ground pin of the IC. This will prevent ground noise from disrupting the loop stability.
- (3) Place R1,R2 and C3 as close to the CN3865 as possible.
- (4) Output capacitor ground and catch diode (D2 in Figure 1) ground connections need to feed into same copper that connects to the input capacitor ground before tying back into system ground.
- (5) Analog ground and power ground (or switching ground) should return to system ground separately.
- (6) The ground pins also works as a heat sink, therefore use a generous amount of copper around the ground pins. This is especially important for high VCC and/or high gate capacitance applications.
- (7) Place the charge current sense resistor R_{CS} right next to the inductor output but oriented such that the IC's CSP and BAT traces going to R_{CS} are not long. The 2 traces need to be routed together as a single pair on the same layer at any given time with smallest trace spacing possible.
- (8) The CSP and BAT pins should be connected directly to the 2 terminals of current sense resistor (Kelvin sensing) for best charge current accuracy. See Figure 4 as an example.

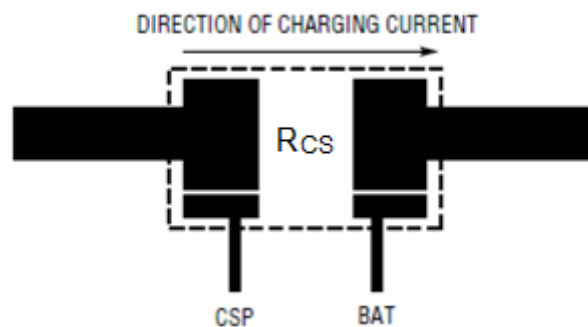
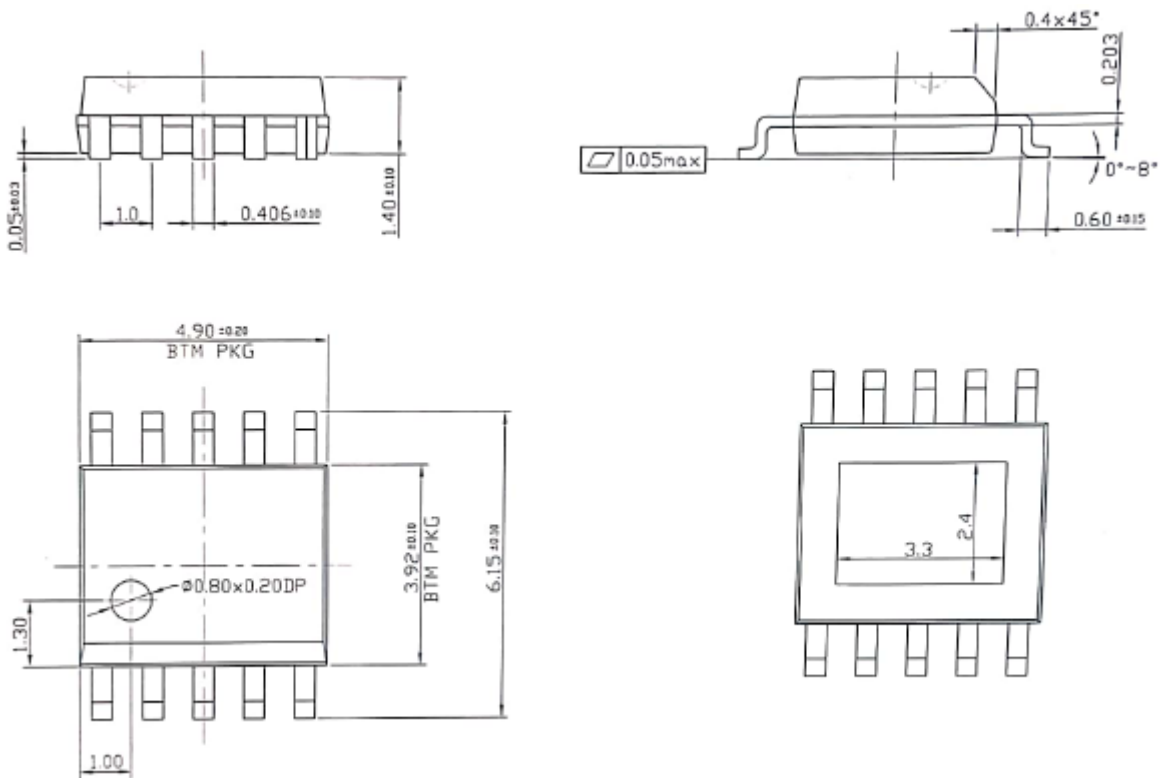

Figure 4 Kelvin Sensing of Charge Current

CONSONANCE

Package Information (eSSOP10)



Important Notice

Consonance Electronics reserves the right to make corrections, modifications, enhancements, improvements and other changes to its products and specifications at any time without notice.

Consonance Electronics assumes no liability for applications assistance or technique support or the use of any circuitry described in the specification during customer product designing and developing. Customers are solely responsible for their products and applications using Consonance Electronics products. Customer should provide adequate design, test and operating safeguard based on its products' operating environment and conditions.